



Lowell è un divano modulare composto da pochi elementi ma capace di creare suggestioni uniche attraverso infinite forme geometriche. Maestoso quando posizionato a parete, completo nelle sue funzioni quando collocato a centro locale, è sempre desideroso di abbinarsi ai tavolini della collezione Luke disegnati per esaltare ancora di più le sue forme tondeggianti. Da qualunque angolazione lo osservi appare sempre arrotondato pur essendo stato progettato e disegnato con una forma quadrata.

Dimensioni

LOWELL.01

Elemento modulare

67 Lx100 Px40 H cm

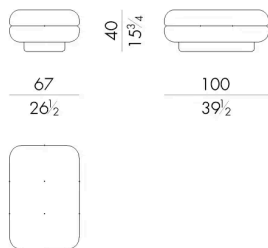

LOWELL.02

Elemento modulare

100 Lx100 Px40 H cm

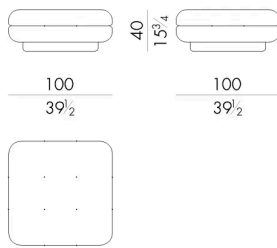

LOWELL.11

Elemento modulare

67 Lx107 Px67 H cm

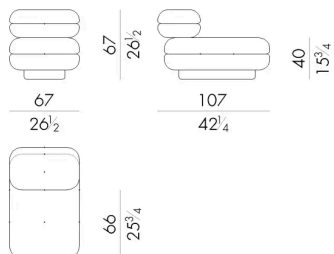

LOWELL.12

Elemento modulare

100 Lx107 Px67 H cm

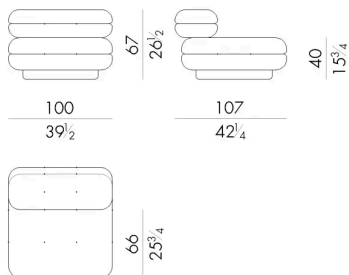

LOWELL . 31 / SX

Elemento modulare

100 L x 107 P x 67 H cm

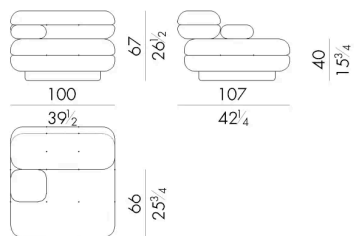

LOWELL . 31 / DX

Elemento modulare

100 L x 107 P x 67 H cm

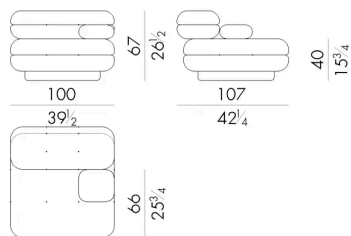

LOWELL . 41 / SX

Elemento modulare

107 L x 107 P x 67 H cm

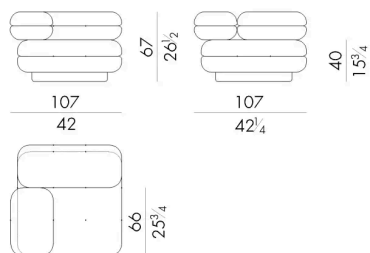

LOWELL . 41 / DX

Elemento modulare

107 L x 107 P x 67 H cm

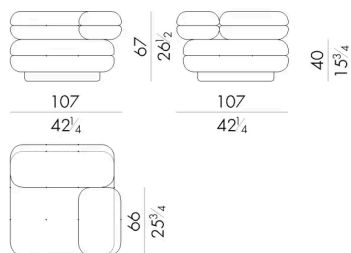

LOWELL. 2200

Divano componibile

200 Lx107 Px67 H cm

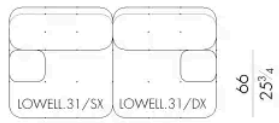
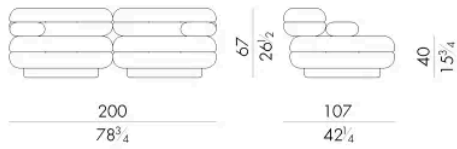

LOWELL. 2400

Divano componibile

267 Lx107 Px67 H cm

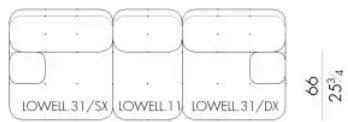
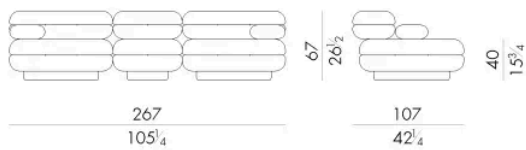

LOWELL. 2600

Divano componibile

334 L x 107 P x 67 H cm

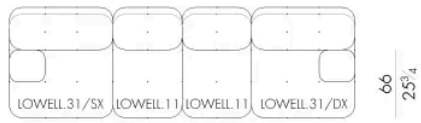
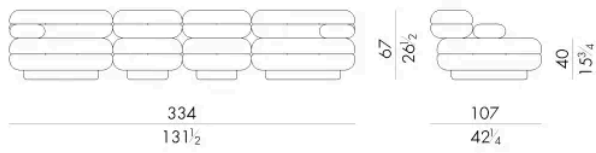

LOWELL. 2650

Divano componibile

334 L x 107 P x 67 H cm

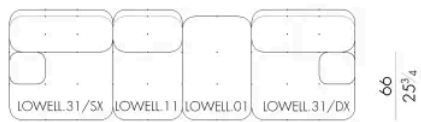
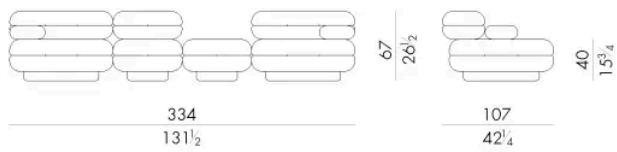

LOWELL . 2700

Divano componibile

400 L x 107 P x 67 H cm

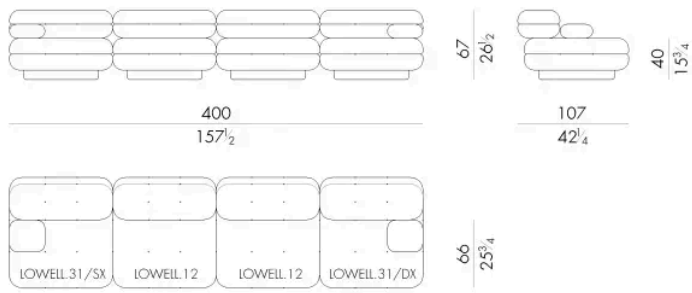

LOWELL . 2750

Divano componibile

400 L x 107 P x 67 H cm

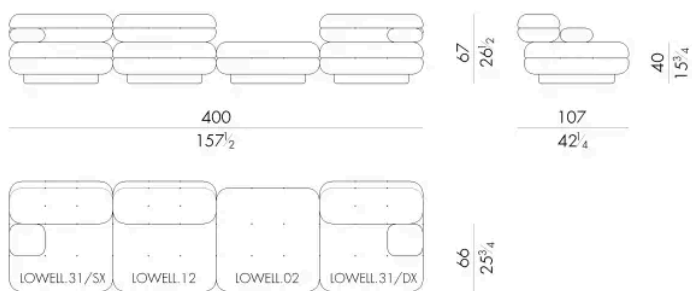

LOWELL.2800/SX - LOWELL.2800/DX

Divano componibile

400 Lx174 P x 67 H cm

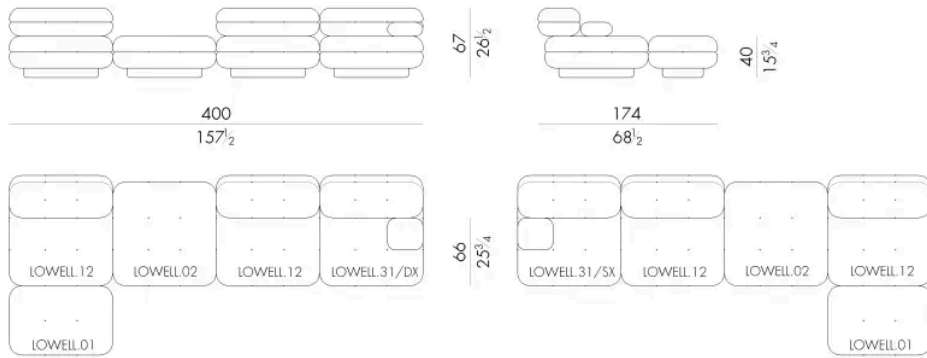

LOWELL.2900

Divano componibile

426 Lx137 P x 67 H cm

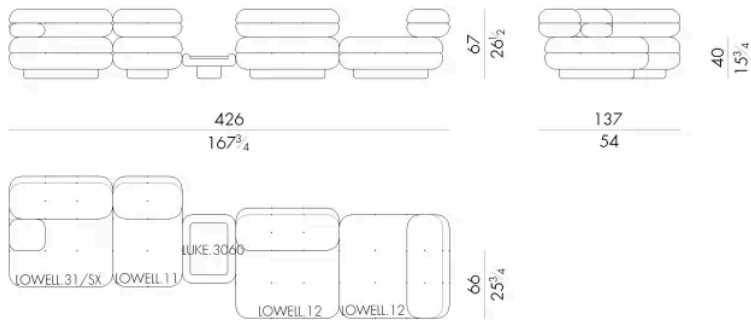

LUKE.3060 not included

LOWELL.3000
Divano componibile

Generato: 27/04/2026

519 L x 267 P x 67 H cm

